

www.japanunix.com



Technology Shaping the Future, One Step at a Time

By applying new ideas today, we hope to bring happiness and innovation to the world.
Taking emotion, even if the difference means only an improvement of 0.1%,
we continuously strive to push the limits of research and development.
And so our technology evolves while we work with our customers
to make their dreams come true.



Soldering Support

At Japan Unix, we provide our customers with comprehensive support using a system that covers the full sales cycle of Pre-Introduction and continues with Post-Introduction/Sales and Service.

Joining the future



SOLDER MEISTER® DF series vol.2

JAPAN UNIX DESKTOP SOLDERING ROBOTS

5 STRENGTHS

p.02 | 1 ACTUAL USES

For on-board electronics in vehicles, as well as mobile electronics, this technology plays an active role in cutting edge developments in a wide variety of fields.



p.04 | 2 MERITS

Many essential features for delivering superior quality automated soldering have been added.



p.06 | 3 STANDARD CONFIGURATIONS

Choose the model best suited for your work.

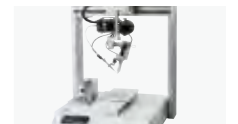

p.08 | 4 STANDARD ROBOT COMPONENTS

The features included in the standard units deliver consistent quality.



p.10 | 5 OPTIONS

Enabling improved maintenance and quality.



p.12 | SPECIFICATIONS

p.13 | PARTS LIST

p.16 | EXTERNAL VIEW DIAGRAM

p.18 | CUSTOMER SUPPORT

At Japan Unix, we offer a comprehensive support system for our customers.



p.20 | GLOBAL NETWORK

● This catalog reflects the products as of July 2017. The product appearance and specifications can change without notice.

● Be sure to carefully read the operating instructions included with the product before use.



UNIX-DF204S



UNIX-DF304S



UNIX-DF404S

Significantly improved robot and heater performance to achieve even better productivity

Equipped with a more accurate heater for improved thermal behavior

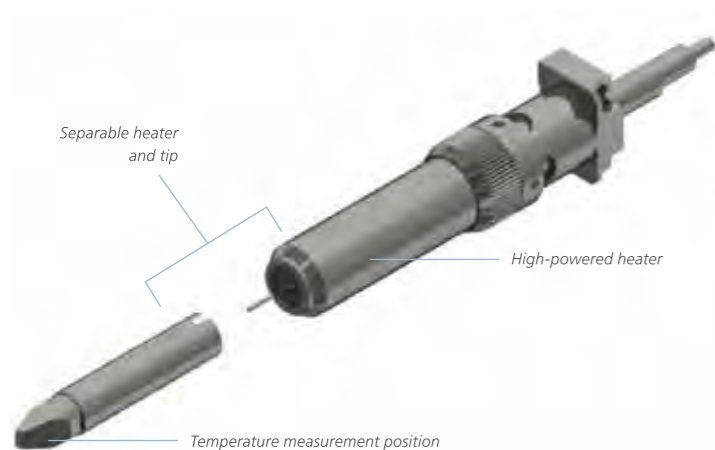

- More accurate temperature behavior achieved by setting the temperature measurement position close to the end of the tip.
- Faster temperature recovery than conventional models for more efficient work.
- Since the heater and tip are separable, they can be replaced independently.
- L-shaped positioning mechanism to prevent incorrect tip mounting.

Thermal behavior at startup

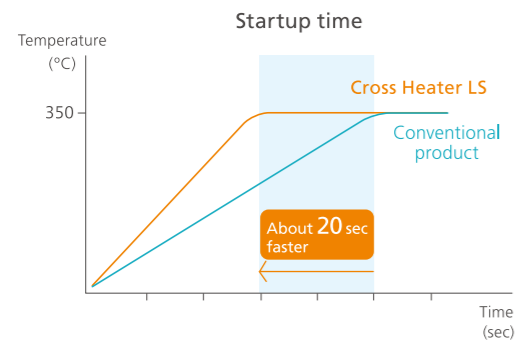

Thermal behavior during soldering

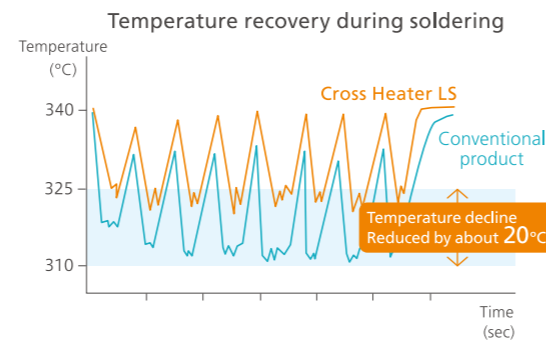

Shortened tact time through increased rigidity and processing speed

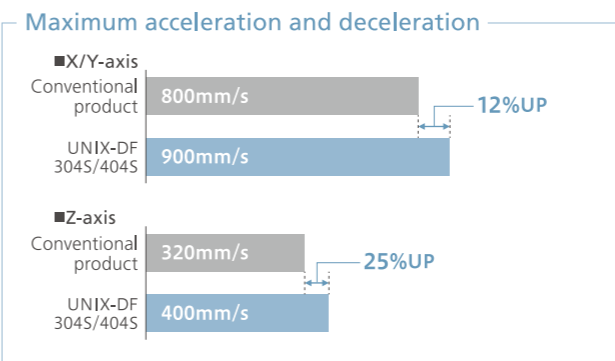
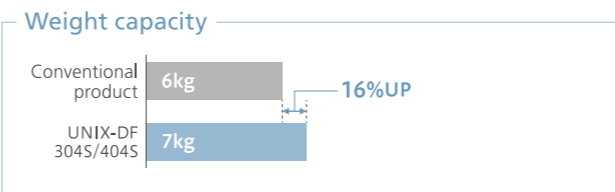
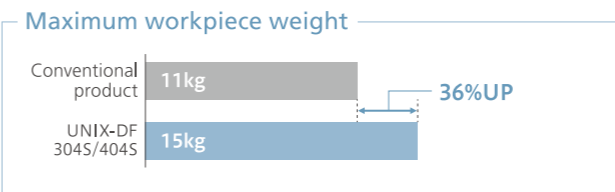

- Mechanism changed from previous model to improve rigidity (UNIX-DF204S).
- Motor changed to improve tool weight capacity and maximum workpiece weight (UNIX-DF304S/DF404S).
- Significant improvements to robot maximum speed and acceleration.
- Improved robot and solder tool processing capacity to reduce tact time.

Easily change programming with the switch box



- Switch box equipped with selector switch.
- Easily select and execute any program. (2 ch.)

Configure settings with the key switch on the front panel



- Quickly check and change temperature settings.
- Capable of auto-tuning after replacing tips.

Simpler and more user-friendly - Easier to operate and maintain

Easily change roller configuration and solder diameter with a new type of solder feeder

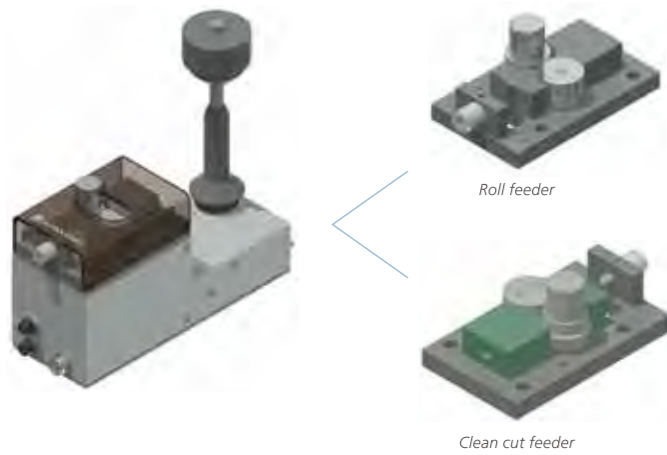

- Change solder diameter just by replacing the feeder block. No adjustments required.
- Easily switch between standard feeder and clean cut feeder by simply replacing the feed block.

Create teaching data during production with the point graphic editing function. OPTION



- Load DXF, Gerber data, image files, etc. for the circuit board to be soldered using specialized PC software and create a robot program on the PC screen.
- Easily switch product types by preparing program data alongside production.

Save up to 999 programs to easily manage data and product types



- Store different product types for each program
- Manage programs for each tip shape or temperature setting.
- Use three-axis position correction with different tip shapes for each program.
- Set counters for each program with the counter function to count three-axis position corrections and cleanings.
- Store detailed settings for each type of product to quickly change setup and programming.

Execute a variety of operations from the teaching pendant

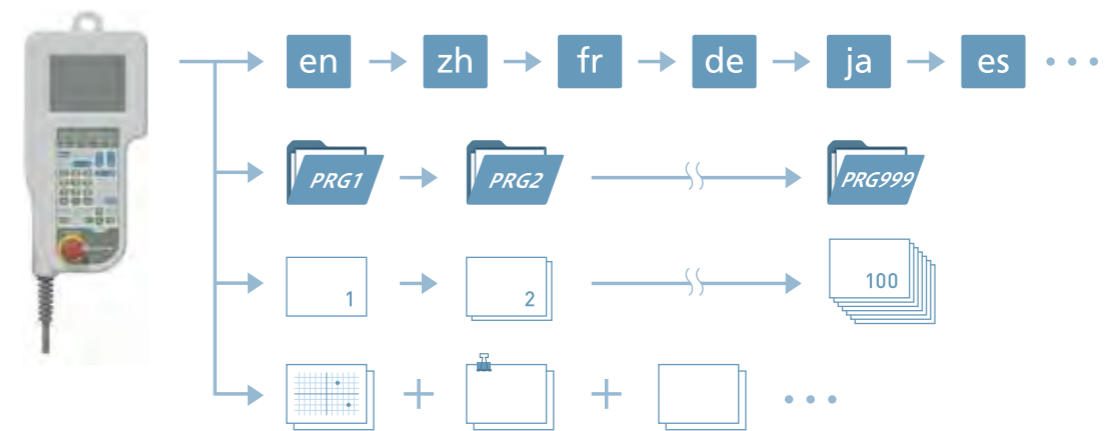

- Supports multiple languages globally. English, Chinese (simplified and traditional), Czech, French, German, Japanese, Korean, and Spanish
- Number of programs
Up to 999
- Number of simple PLC recordings
Up to 100
- Coordinate registration, etc. for image processing
- Additional axis control.

2 MERITS 3

Network functions strengthened in anticipation of upcoming "Industrie 4.0" standards

Connect to factory network for real-time visualization OPTION

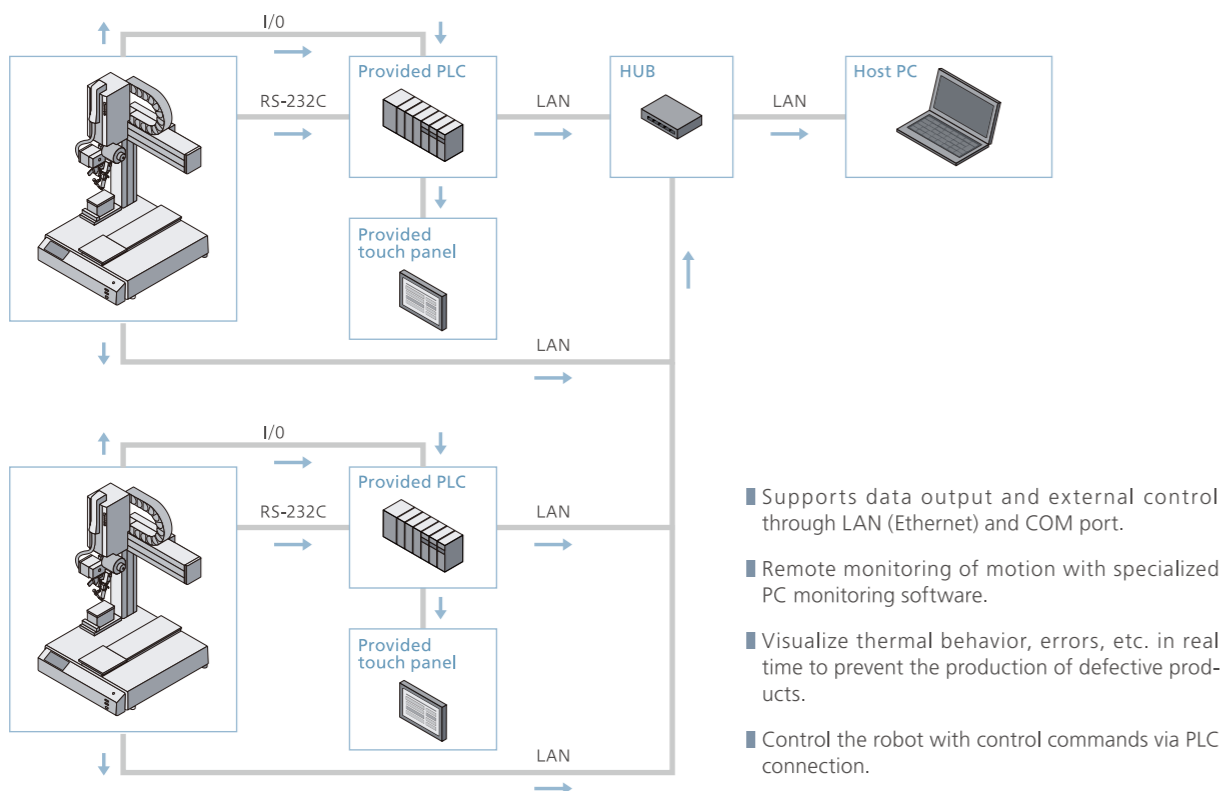

Easily output data with the LAN/USB memory port

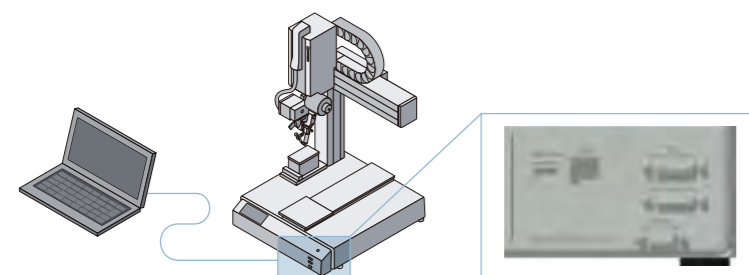

- Standardly equipped with a LAN/USB memory port.
- Save and load backup data with a USB memory drive.

2 MERITS 4

Achieve 3D soldering

Easily solder products with complicated shapes using two additional axes OPTION

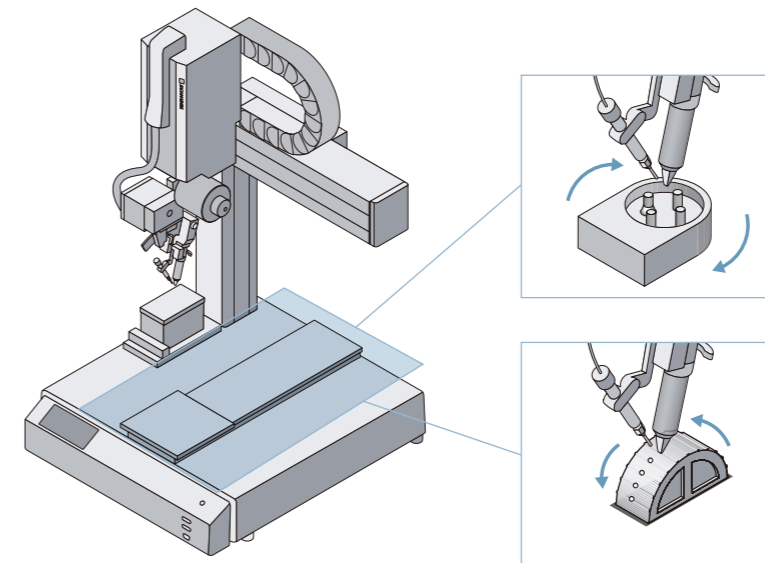

- Add 2 axes to the standard 4 axes for a maximum total of 6 axes.
- Control all robot operations and external equipment by robot at once.
- Allows for piece rotation, circuit board rotation, angular tilt, rotation of cylindrical parts, cable control, and more.
- Space-saving and easy to configure.

Also equipped with a laser soldering process OPTION



- DF-Series can be equipped with laser soldering tools.
- Achieve even more accurate soldering.

* Please contact your sales representative for more information.

Various model configurations deliver maximum effectiveness

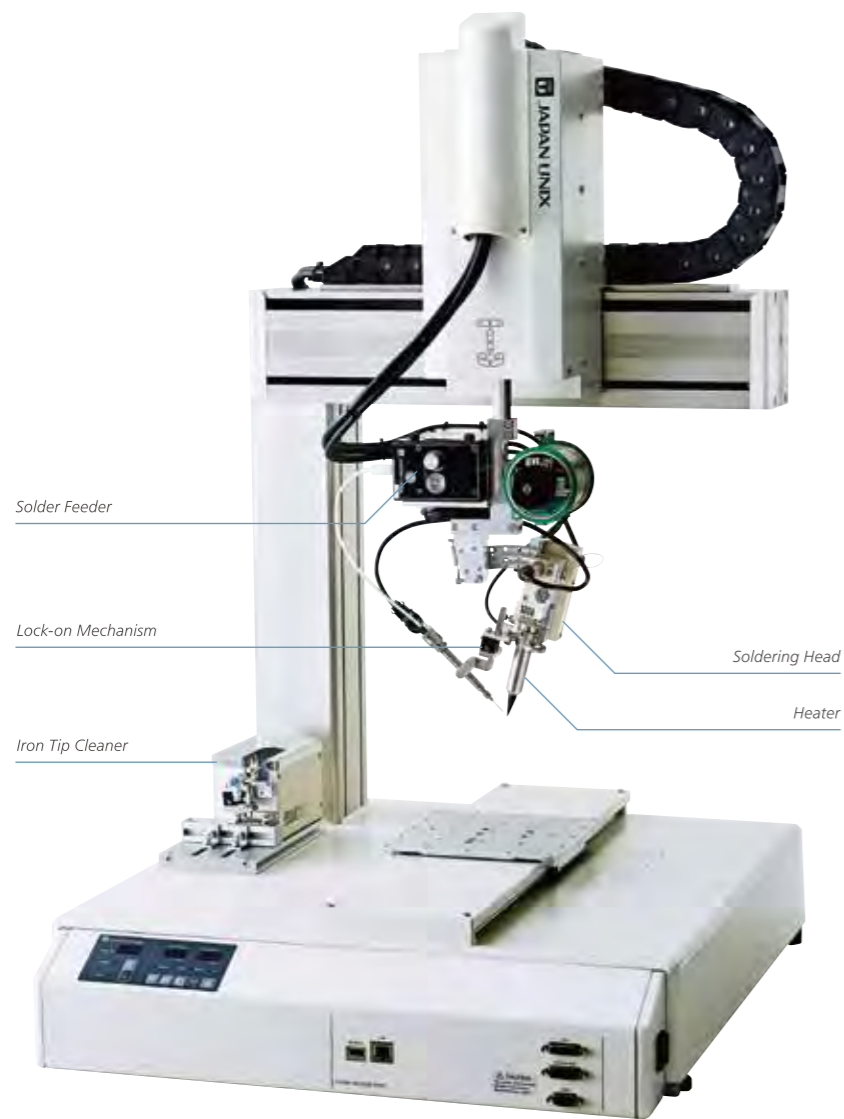

UNIX-DF404S



Switch Box

Teaching Pendant



UNIX-DF204S



UNIX-DF304S

Robot Set Details (For UNIX-DF204S / 304S / 404S)

Soldering controller	UNIX-DF204S	DF-UPC-12S
	UNIX-DF304S / 404S	Incorporated into the main body
Soldering Head	UNIX-DF204S	Point type : choose from UMC-093A-BHS / UMC-093A-BHL. Linear type (option) : choose from UMC-093AS-BHS / UMC-093AS-BHL.
	UNIX-DF304S / 404S	Choose from UMC-090-BHS / UMC-090-BHL
Solder Feeder	UNIX-DF204S	Choose from UPM-057 / UPM-057CC
	UNIX-DF304S / 404S	Choose from UPM-056 / UPM-056CC
Iron Tip Cleaner with Vacuum Function		Standard:UJC-214CWII / Lock-on:UJC-214CWII L0(0°)/ L10(10°)
Lock-on Mechanism(UNIX-DF304S/404S) [※]		Model number differs depending upon specifications. (See p.17)
Tube Set		Model number varies depending on solder diameter used. (See P.18)
Switch Box		DF-SBU (Cable length is 1.5m.)
Teaching Pendant		DF-TPU (Cable length is 2m.)
PC software		DF Editor SJ (Japanese) / DF Editor SE (English)

※Optional on the UNIX-DF204S.

Standard-equipped with more advanced soldering units

Soldering Robot Heads PATENTED

- Select from two types of heaters.
- Standard equipped with solder supply lock-on mechanism. (UNIX DF304S/404S)^{※1}
- Heater block can be easily detached, and tip and heater can be replaced in approximately one minute.

※1 Optional equipment for the UNIX-DF204S.

[Heater block]

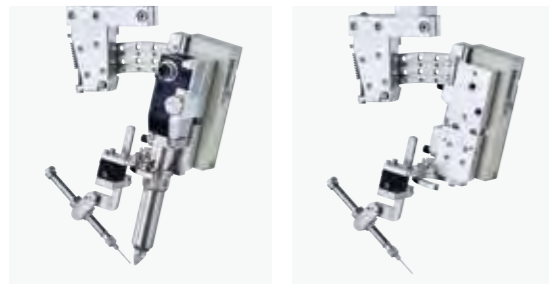

Attached

Removed

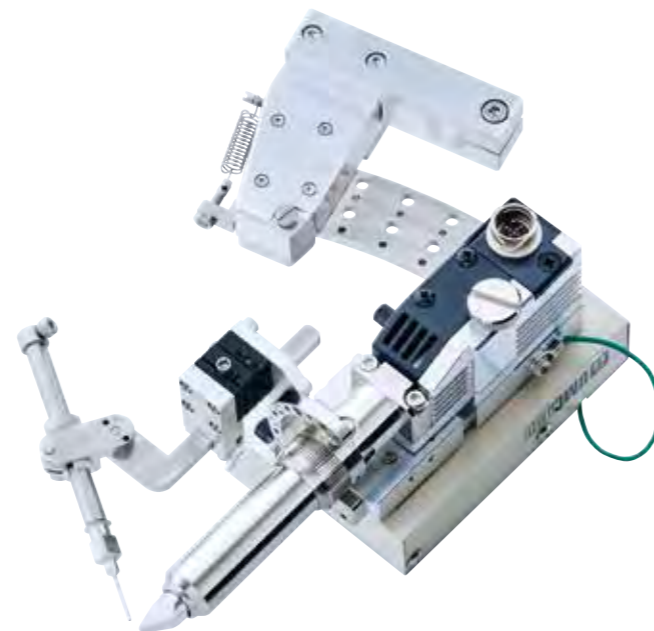

Lock-on Mechanism PATENTED ^{※2}

- Angle block with memory provides stabilization and prevents solder supply position misalignment that can easily occur during maintenance.
- Perfectly maintains the original supply position.

※2 Optional equipment for the UNIX-DF204S.



Solder Feeder PATENTED

- Encoder detects errors such as solder shortage, jamming, and slippage.
- Improves solder feeding precision.
- Proprietary mechanism enables one-touch solder reel replacement.
- Clean Cut accessory available as standard option.

[Clean Cut type solder cross section]

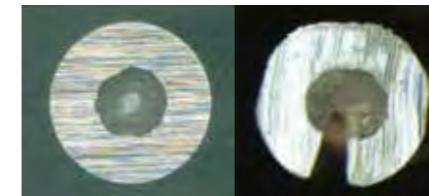

Before cut

After cut

Making an incision into the solder reduces solder balls and flux dispersion by 90% or more.^{※3}

※3 Clean Cut results will vary according to the solder material used. Some solder materials are incompatible; please contact us for details.

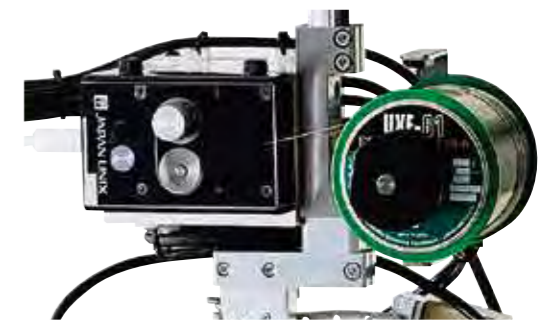

Clean Cut Type

Iron Tip Cleaner with Vacuum Function

UJC-214CW II L0(0°) / L10(10°)

- Air blower-style iron tip cleaner.
- Vacuum system reduces solder scattering during cleaning.
- Air blower nozzle angle adjustment is based on a lock-on mechanism, making angle resetting easy.



High-performance options to maintain higher-quality soldering

Three-Axis Tip Position Corrector UCS-410S-SET

PATENTED

- An automatic position corrector for the UNIX-DF Series.
- Quickly and automatically corrects position gap due to tip erosion and/or thermal expansion.



Double Brush Cleaner UJC-217

- Rotates two wire brushes to remove stubborn buildup on the end of the iron tip.
- Effectively cleans carbonization, tin oxides, and other materials that cannot be removed by the standard iron tip cleaner.



Added control axes (up to 2 axes)

- Add two additional axes to XYZR, up to a maximum of six simultaneously controlled axes.
- Piece rotation, circuit board rotation, angular tilt, rotation of cylindrical parts, cable control, and more can be controlled all at once.

· The mechanism is custom-designed.

Point graphic editing function

- Edit images of the circuit board to be soldered with special PC software to determine and configure teaching points more accurately.
- Possible to import DXF, jpeg, Gerber data, and more.



Solder Wire Preheater ※1 SHN-41S-※※

- Preheats solder wire to reduce solder balls and flux dispersion due to sudden heat shock during soldering.
- Also effective at reducing tact time.



※※ = Solder diameter

※1 Cannot be used with Clean Cut Feeder.

Clean Cut Feeder ※2

PATENTED

- Reduces the occurrence of flux spatter and solder balls by putting notches into the solder as it is fed through.
- The special two-blade method ※3 stabilizes solder feeding and prevents solder slippage.



※2 Cannot be used with Solder Wire Preheater

※3 Solder diameter: φ0.5, φ0.6, φ0.65, φ0.8 and φ1.0 only.

Vision Position Correction Sensor

- Detects target shape with a camera and automatically corrects misalignments in the workpiece.



Digital Thermometer UNISENSOR-701A

- Digital thermometer for tip temperature measurement.
- Handheld design makes for easy measurement of installed tip temperature. Ideal for routine temperature management.



Nitrogen Gas Generator UNX-200

- Creates a nitrogen gas environment to improve the workability of lead-free solder.
- Protection against oxidation and improves spread and wettability.



Iron Tip N2 Cap

- Blows nitrogen gas from the end of the iron tip.



Fume Extractor UAC-2000

- Extracts flux fumes during soldering.
- Dual filters for removal of fumes.
- Equipped with external input/output terminals.



· Three-level suction adjustment and filter clog sensor.

· Dimensions: W340xD360xH477 (mm) (excluding protrusions)

· Weight: Approx. 18.5Kg

Fume Extraction Duct Set

- Duct for fume extractor that attaches to soldering robot.

· Type varies according to equipment model used.



Nitrogen gas concentration monitor UNX-M2

- Displays nitrogen gas concentration by separating off and directing nitrogen gas to the sensor.
- Standardly equipped with alarm output and analog output. Connect with and operate a revolving light or recorder.



- Ideal nitrogen gas concentration at the time of soldering.

Remaining solder sensor

- When solder is running out, the sensor detects its existence and alerts that it needs to be replaced.





A wide range of soldering iron tips

We offer a standard line up of tip shapes for point soldering and linear soldering.

· Please contact us regarding our tip shape lineup, special shapes, or other details.

SPECIFICATIONS

		UNIX-DF204S	UNIX-DF304S	UNIX-DF404S
Number of axes		4 standard axes, 2 additional axes (optional), for up to 6 simultaneously controlled axes		
Range of operation	X-axis	200mm	300mm	400mm
	Y-axis	250mm	320mm	400mm
	Z-axis	50mm	100mm	100mm
	R-axis	±360°	±360°	±360°
Maximum movable weight (workpiece)		7kg	15kg	15kg
Maximum speed ^{※1} (PTP)	X-axis, Y-axis	600mm/sec	900mm/sec	900mm/sec
	Z-axis	250mm/sec	400mm/sec	400mm/sec
	R-axis	600 °/sec	900°/sec	900°/sec
Maximum speed ^{※1} (CP)		X/Y/Z-axis composite 600mm/sec	850mm/sec	850mm/sec
Repeatability accuracy ^{※2}	X-axis, Y-axis	±0.01mm		
	Z-axis	±0.01mm		
	R-axis	±0.008°		
	Workpiece size (maximum jig size)	200mm×210mm	300mm×275mm	400mm×365mm
Position teaching method		Remote teaching (JOG) / Numerical input (MDI)		
Teaching format		Direct teaching via teaching pendant / Offline teaching via PC software		
Number of programs		999 programs		
Point memory capacity ^{※3}		Up to 32,000 points		
Drive system		5-phase pulse motor drive		
Control system		PTP control, CP control		
Interpolation function		3D linear interpolation, 3D circular interpolation		
External I/O	I/O-SYS	Input: 16 points, Output: 16 points		
	I/O-1	Input: 8 points, Output: 8 points(Includes 4 relay outputs.)		
	I/O-MT / I/O-S	I/O-MT: For external monitor control (optional) I/O-S: For interlocking devices such as area sensors		
	I/O-A / I/O-B / I/O-C	I/O-A: For air cleaner connection I/O-B: For brush cleaner connection I/O-C: For position correction unit connection		
	COM1	RS-232C (For external device control, COM command)		
	COM2 / COM3	RS-232C (For external device control)		
	MEMORY	For USB memory connection (save and load teaching data, update system software)		
	LAN	For connecting to a PC via Ethernet (10Base-T/100Base-T) (Robot control with control commands, connecting to PC software)		
Simplified PLC function		100 programs, 1,000 steps/program		
Number of solder conditions		255 conditions		
Iron tip temperature control range		200-450°C		
Heater alarm value		Configure upper temperature deviation limit: 5°C to 99°C Configure lower temperature deviation limit: -5°C to -99°C		
Heater power		250W: Cross Heater LS / Cross Heater L		
Supported solder diameter ^{※4}		φ0.3-φ1.2(Standard) φ0.5-φ1.0(Clean Cut Type)		
Alarm indicators		Disconnected heater / disconnected temperature sensor / solder clog, etc.		
Dimensions (W×D×H)		413×387×706(mm)	560×575×934(mm)	584×635×934(mm)
Power supply		AC100-120V 50/60Hz 550W(VA) AC220-240V 50/60Hz 550W(VA)		
Air		Dry air, 0.5MPa		
Operating temperature		0-40°C		
Relative humidity		20-95% (non-condensing)		
Weight		Approx. 35kg	Approx. 45kg	Approx. 52kg

※1 Maximum speed varies depending upon conditions. Please note that the maximum speed is not shown with the maximum payload capacity setting.

※2 Repeatability of positioning only applies if the body temperature is constant. Furthermore, there is no guarantee of the absolute position.

※3 Storage area is shared, so the number of point data recordings possible will be reduced if point attribute data, point work data, or PLC program data increase.



※4 The diameter of solder applied may not be possible depending upon the manufacturer and material used. We recommend testing in advance.

※5 You must connect to the optional power supply unit if connecting to an AC 200-240V power source.

※6 Power consumption varies depending upon the type of heater used. Maximum values are displayed.

PARTS LIST

Soldering Heads/Heaters

Soldering head model number	Compatible heater name	Compatible heater model number	Compatible tips	Output power	Model number of supported robot
UMC-093A-BHS UMC-093AS-BHS [※]	 Cross Heater LS	100BHS-2510	Cross-Bit LS series	250W	UNIX-DF204S
UMC-090-BHS					UNIX-DF304S UNIX-DF404S
UMC-093A-BHL UMC-093AS-BHL [※]	 Cross Heater L	100BH-2510	Cross-Bit L series		UNIX-DF204S
UMC-090-BHL					UNIX-DF304S UNIX-DF404S

[※] option

Soldering Heads

UMC-093A-BHS / UMC-093A-BHL(For point soldering)	UMC-093AS-BHS / UMC-093AS-BHL(For linear soldering)	UMC-090-BHS / UMC-090-BHL
		

Lock-on Mechanism

Product Image	Model number	Solder preheating (○ = yes)	Soldering method	Remarks
	LOS87-75**XY		Linear solder	**=Solder supply angle : 30 (for 30° application) 25°/30°/35°
	LOS87-75**HXY	○		
	LOP87-75**XY		Point solder	**=Solder supply angle : 45 (for 45° application) 35°/40°/45°/50°/55°/60°
	LOP87-75**HXY	○		

[•]All lock-on mechanism models include an XY adjustment mechanism.

Iron Tip N2 Cap

Product Image	Model number	Remarks
	100BHS-N2-CA	N2 nozzle (NZS**) included
	100BH-N2-CA-YZ	N2 nozzle (YNZ**) included

PARTS LIST

Standard Solder Feeder Parts

Solder Feeder Spare Parts

Product Image	Name	Model number	Remarks
	Roller unit	UPM-023RF-RU**	** = Wire diameter specification; e.g., 05 = φ0.5 φ0.3/φ0.4/φ0.5/φ0.6/φ0.65/φ0.8/φ1.0/φ1.2
	Inlet nozzle	UPM-023RF-INZ** ^{※1}	
	Center nozzle	UPM-023RF-CNZ** ^{※1}	
	Outlet nozzle	UPM-023-ONZSS	For wire diameter φ0.3-φ0.4
		UPM-023-ONZS	For wire diameter φ0.5-φ0.65
UPM-023-ONZM		For wire diameter φ0.8	
	UPM-023-ONZL	For wire diameter φ1.0-φ1.2	

※1 Nozzles are common for φ0.6 and φ0.65(**=06)

Solder Supply Components (Standard)

Product Image	Wire diameter	Needle	Needle holder	Tube set	Tube set overall length
	φ1.2	ND-15GP	CL-S-3	PT12S-040	400mm ^{※2}
	φ1.0	ND-16GP	CL-S-2	PT10S-040	
	φ0.8	ND-17GP		PT08S-040	
	φ0.6/φ0.65	ND-18GP		PT06S-040	
	φ0.5	ND-19GP		PT05S-040	
	φ0.4	ND-20GP		PT04S-040	
	φ0.3	ND-21GP		PT03S-040	

※2 Lengths other than 400mm are also available (special order)

Solder Supply Components (High Precision)

Product Image	Wire diameter	Needle	Needle holder	Tube set	Tube set overall length
	φ0.8	SND-10	CL-S-2	PT08S-040	400mm ^{※2}
	φ0.6/φ0.65	SND-08		PT06S-040	
	φ0.5	SND-07		PT05S-040	

※2 Lengths other than 400mm are also available (special order)

Clean Cut Type Solder Feeder Parts

Solder Feeder Spare Parts

Product Image	Name	Model number	Remarks
	Roller unit	UPM-023CC-RU**	** = Wire diameter specification; e.g., 06 = φ0.6 φ0.5/φ0.6/φ0.65/φ0.8/φ1.0
	Inlet nozzle	UPM-023CC-INZ** ^{※1}	
	Center nozzle	UPM-023CC-CNZ** ^{※1}	
	Outlet nozzle	UPM-023-ONZS	For wire diameter φ0.5-φ0.65
		UPM-023-ONZM	For wire diameter φ0.8
UPM-023-ONZL		For wire diameter φ1.0	

※1 Nozzles are common for φ0.6 and φ0.65(**=06)

Solder Supply Components (Clean Cut Type)

Product Image	Wire diameter	Needle	Needle holder	Tube set	Tube set overall length
	φ1.0	ND-15GP	CL-S-3	PT10SCC-040	400mm ^{※2}
	φ0.8	ND-16GP	CL-S-2	PT08SCC-040	
	φ0.6/φ0.65	ND-17GP		PT06SCC-040	
	φ0.5	ND-18GP		PT05SCC-040	

※2 Lengths other than 400mm are also available (special order)

EXTERNAL VIEW DIAGRAM

UNIX-DF204S

Units: mm

Top view

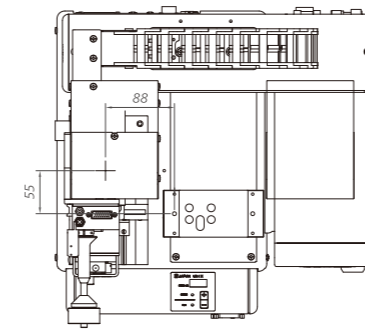

Jig mounting surface (X-axis table)

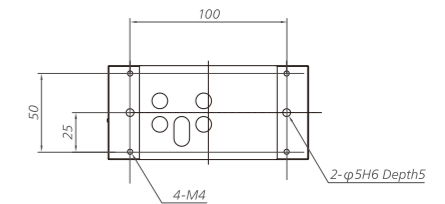

Front view

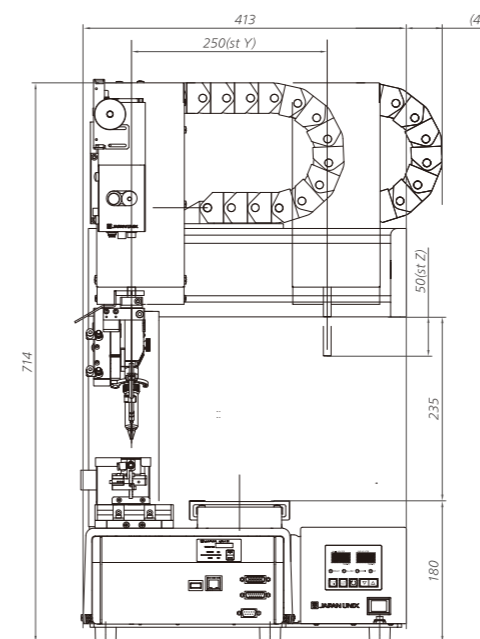

Side view

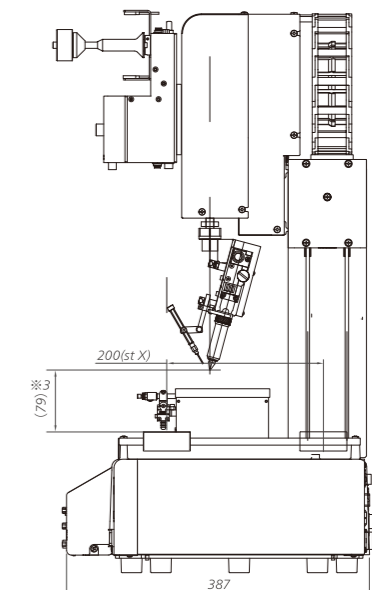

※3 When using Cross Heater LS (75°, point type).
The clearance between iron tip and X table differs depending on type of soldering head.

EXTERNAL VIEW DIAGRAM

UNIX-DF304S

Units: mm

Top view

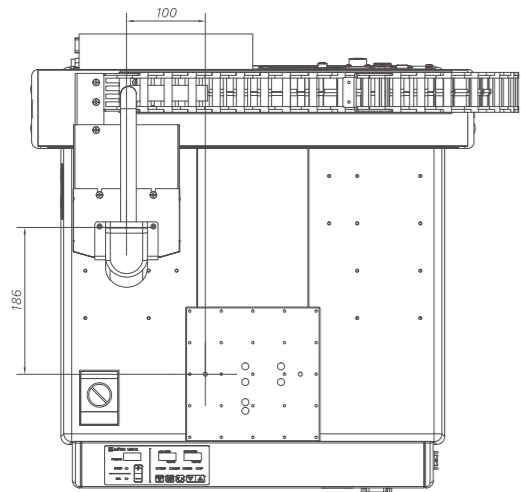

Jig mounting surface (X-axis table)

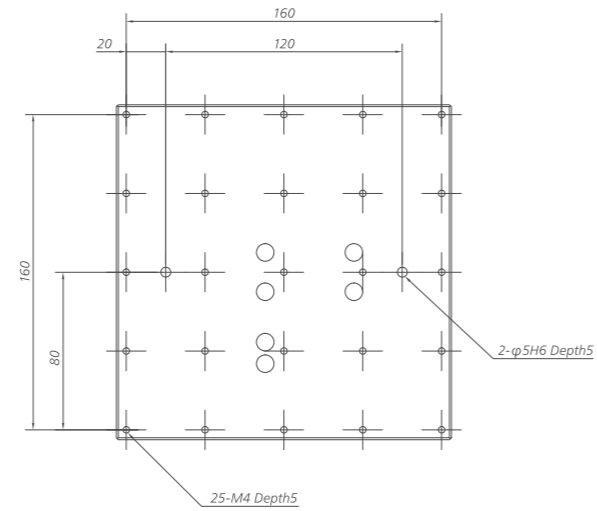

Front view

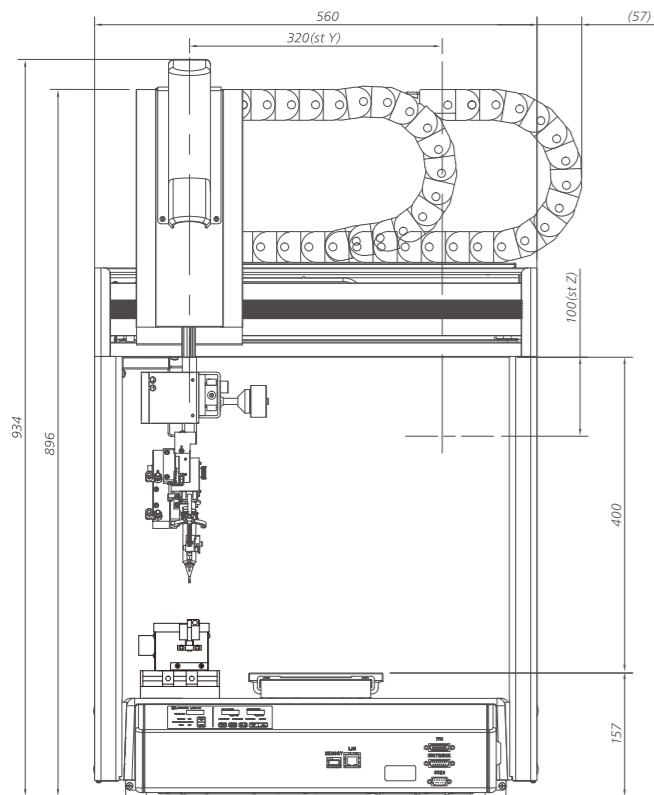

Side view

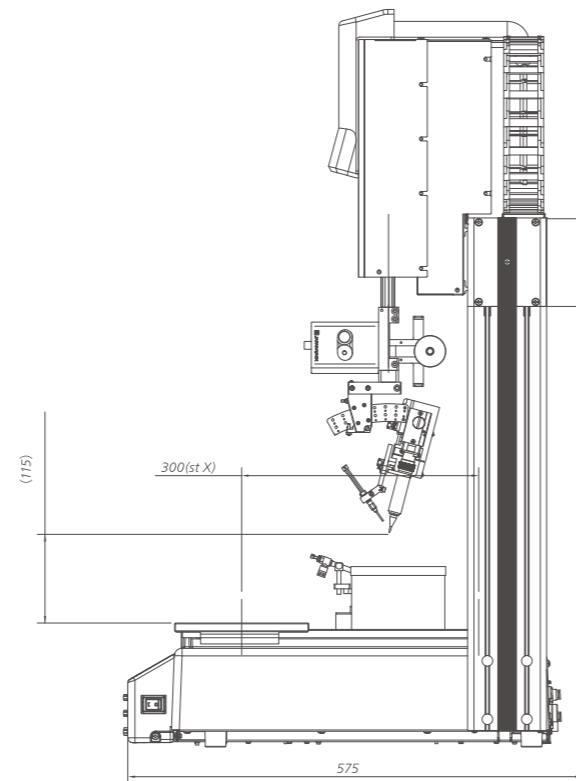

UNIX-DF404S

Units: mm

Top view

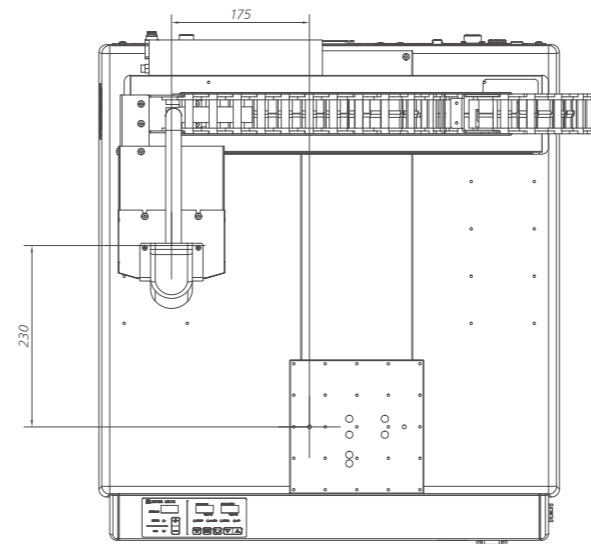

Jig mounting surface (X-axis table)

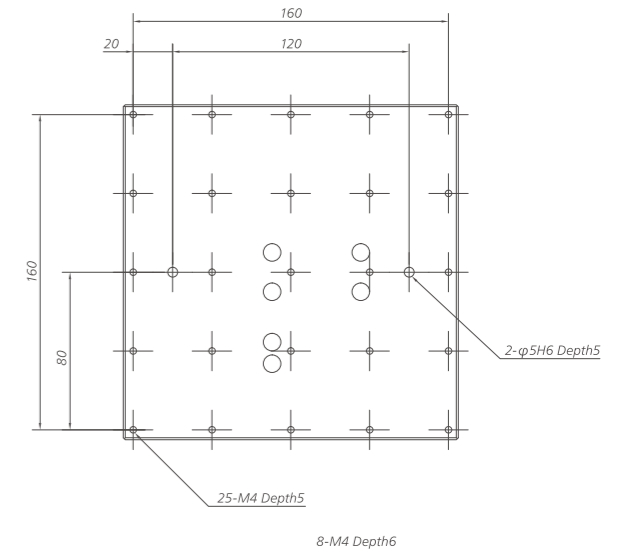

Front view

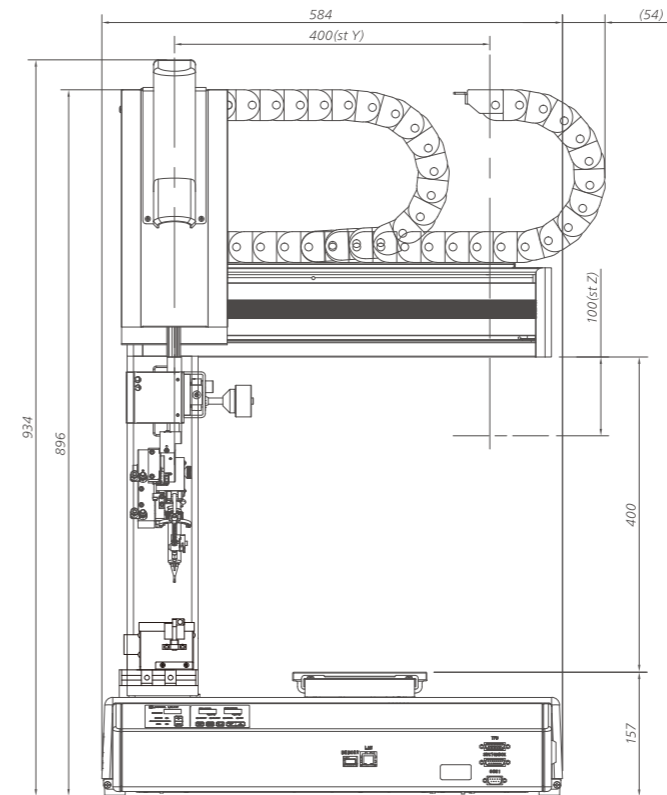

Side view

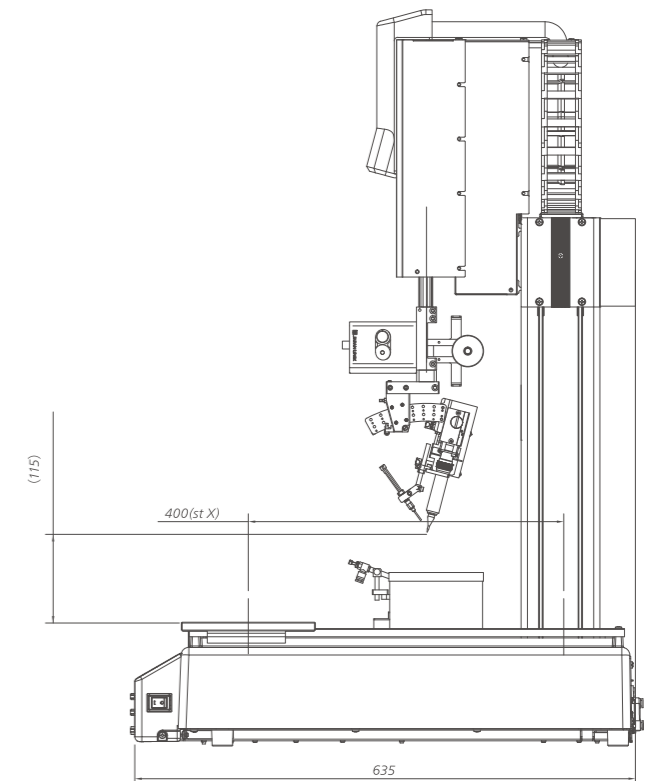

Comprehensive customer support structure provided by soldering engineers



Soldering Support

In the manufacturing world, there is nothing more important than having someone you can trust when you run into unexpected trouble. The soldering specialist engineers at Japan Unix provide our customers with a comprehensive support structure from prior to your purchase to after the installation. This ensures continuous, safe, secure high quality manufacturing.

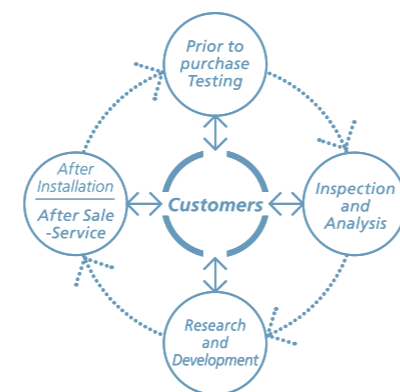

Testing and Analysis Prior to Purchase

We preform soldering operation testing using systems that are identical to the ones the customer is considering for purchase. At Japan Unix we make maximum utilization of our soldering technology and experience to perform experiments, inspect results and only then suggest the ideal soldering structure and system.

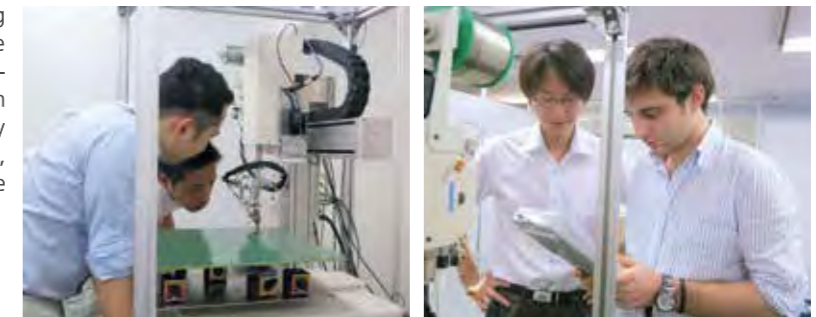

Design Support Service

In order to improve soldering operation efficiency and quality control, we provide a comprehensive range of processes from circuit board design to mass production.

Soldering Laboratory

The latest Japan Unix products are installed at our lab which is used for performing research and development of soldering technology, in addition to the testing procedures prior to purchase. It is also a place frequently used by worldwide customers, and has become something of an international soldering conference office. Also, in our soldering lab annex we analyze soldering joints in finer detail using state of the art optical and measurement systems. This plays a further role in the development of innovative products.



After-Service

To enable customers to operate in a more comfortable environment, we respond promptly to requests after the purchase for changes to system settings, software update, and repairs, among others. Please feel free to make an inquiry at any time.



Soldering School (Certification Exam)

We regularly offer soldering classes which in a short period of time provide basic soldering techniques and knowledge. (Only in Japan)

※This program is based on The Japan Welding Engineering Society's "Micro-Soldering Technician Certification," and attendees can take the certification exam on the final day of the program.
※For more information, please contact the business supervisor or our school staff.



IPC Standards

IPC standards are manufacturing quality standard designed by IPC association, which are accepted by electronics manufacturers and purchasers worldwide.

At Japan Unix, we exclusively provide standards documents, information and services in Japan.















 Distributors

-  North and Central America USA, Canada, Mexico
-  Europe UK, Italy, Finland, France, Germany, Norway, Spain, Czech Republic, Slovakia, Hungary, Romania, Turkey
-  Russia Saint Petersburg
-  East Asia China (Shanghai, Suzhou, Beijing, Shenzhen, Chengdu, Chongqing, Xian, Hong Kong), S.Korea, Taiwan
-  Southeast Asia Indonesia, Malaysia, Philippines, Singapore, Thailand
-  Southern Asia India
-  Oceania Australia
-  Africa South Africa

 Japan Unix Offices

-  Headquarters 2-21-25 Akasaka, Minato-ku, Tokyo 107-0052
TEL: +81-3-3588-0551 (Rep.) FAX: +81-3-3588-0554
-  Osaka Office 3F, 3-27-27 Tarumi-cho, Suita-shi, Osaka 564-0062
TEL: +81-6-6190-4580 FAX: +81-6-6190-4581
-  Nagoya Office 8F, 1-7-5 Kanayama-cho, Atsuta-ku, Nagoya-shi, Aichi 456-0002
TEL: +81-52-679-2111 FAX: +81-52-679-2112
-  Techno Center 2020-3 Oaza Tabaru, Mashiki-machi,
Kamimashiki-gun, Kumamoto 861-2202
TEL: +81-96-287-4501 (Rep.) FAX: +81-96-287-4503
-  Korea Office
-  Shanghai Office
-  Shenzhen Office
-  Taiwan Office
-  Malaysia Office
-  Mexico Office
-  U.S.A Office